

FULLY AUTOMATIC PROCESSING
WITH MULTIPLE BATCH SYSTEM
VAF/B540

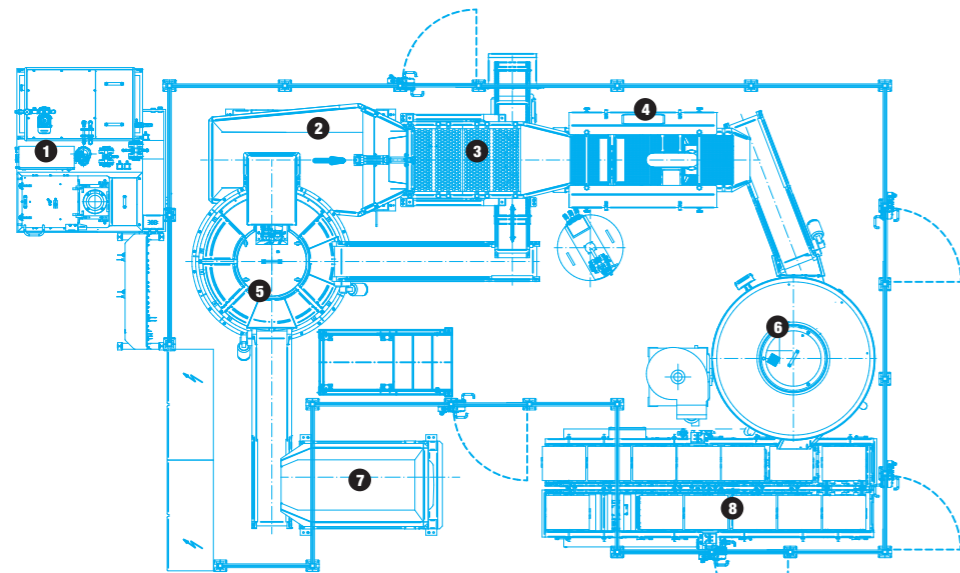

- 1 Recycling centrifuge
- 2 Vibrator conveyor chute
- 3 Vibratory screening device
- 4 Shower device with blowing unit
- 5 Round tub vibrator VAF/B540
- 6 Parts hopper
- 7 Roller conveyor
- 8 Roller conveyor system

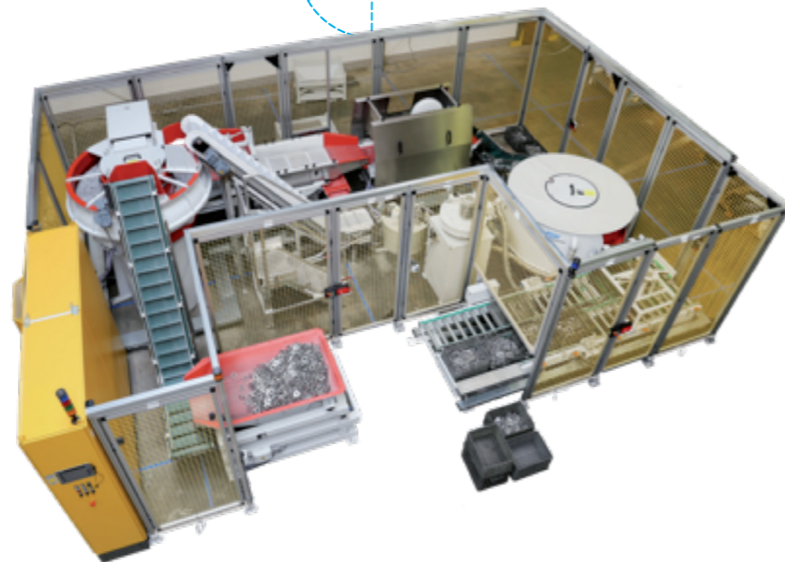

ROUNDTUB VIBRATORS
VAF/B



VAF

© SPALECK ENGINEERING

**Deburring · Edge Rounding · Cleaning
Shining · Polishing**

Equipped for a complete discharge of parts and media after processing thanks to a pneumatic bottom discharge flap. Suitable as a fully automatic complete system for multi-batch operation.



MADE IN GERMANY

Misprints, mistakes and construction deviations reserved.

www.bn-medienagentur.de

VAF - VAF/B - eng · 11 · 2022

ROUNDTUB VIBRATOR VAF/B340

Technical features:

- Pneumatic bottom discharge flap to feed parts and processing media into an external separation unit
- Elevated stand to combine the machine with post-treatment units
- Tub lining made of wear-resistant polyurethane

Optional features:

- Frequency converter for a continuous adjustment of the motor speed
- Easily removable sound protection segments

Technical data:

Description	VAF/B340	
Working tub volume	l	340
Operating voltage	V Hz	400 50
Drive power	kW	2,9
Motor speed	Rpm	1460
Empty weight basic machine	kg	1060
Operating weight max.	kg	2260
Space requirement basic machine	m ²	3

ROUNDTUB VIBRATOR VAF/B540



Technical features:

- Pneumatic bottom discharge flap to feed parts and processing media into an external separation unit
- Elevated stand to combine the machine with post-treatment units
- Tub lining made of wear-resistant polyurethane
- Curved walls of the working tub

Optional features:

- Frequency converter for a continuous adjustment of the motor speed
- Easily removable sound protection segments

Technical data:

Description	VAF/B540	
Working tub volume	l	540
Operating voltage	V Hz	400 50
Drive power	kW	6,5
Motor speed	Rpm	1460
Empty weight basic machine	kg	1600
Operating weight max.	kg	3100
Space requirement basic machine	m ²	3

Dimensions in mm:

Description	VAF/B340	
Diameter working tub	A	1500
Width working tub	B	325
Bottom edge discharge flap	C	870
Bottom edge drain siphon	D	990
Height base	E	940
Height working tub	F	448
Top edge working tub	G	1585
Top edge vibrator	H	1810
Width vibrator incl. bottom discharge unit	I	1690
Width bottom discharge unit	J	360

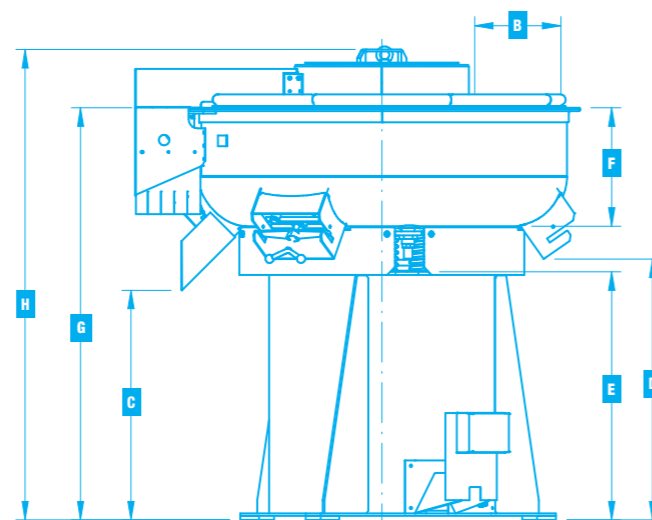
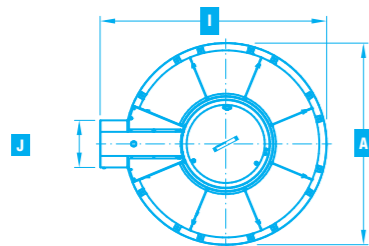

© SPALECK ENGINEERING

Dimensions in mm:

Description	VAF/B540	
Diameter working tub	A	1730
Width working tub	B	387
Bottom edge discharge flap	C	1290
Bottom edge drain siphon	D	1320
Height base	E	1320
Height working tub	F	535
Top edge working tub	G	2070
Top edge vibrator	H	2250
Width vibrator incl. bottom discharge unit	I	2040
Width bottom discharge unit	J	610

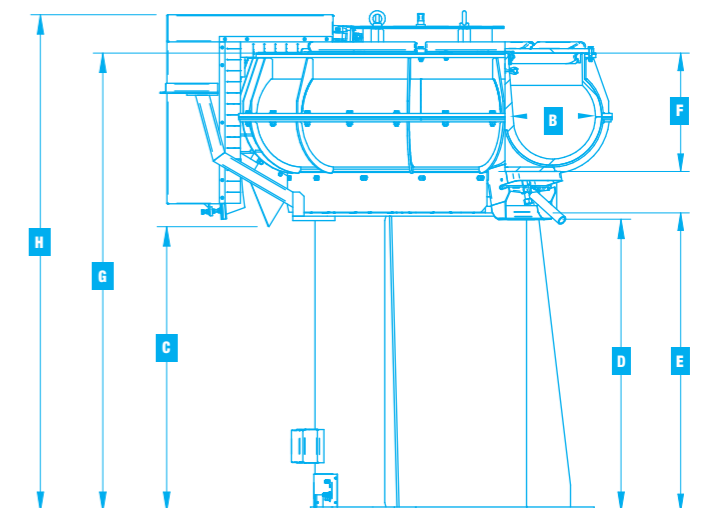
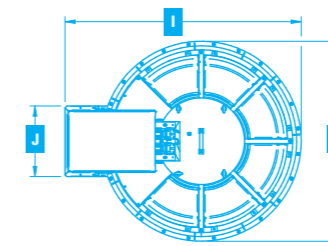

© SPALECK ENGINEERING