



Surface finishing

Edge-breaking

Ball-burnishing

Deburring

Shining

Centrifugal finishing machines Z1/Z2



SP/LECK
Oberflächentechnik

90

60

90

120

150

180

Centrifugal finishing machines Z1/Z2



- ▲ The Z1/Z2 centrifugal finishing machine is especially suitable for the treatment of sensitive parts with small dimensions as well as for small batches with very high demands on the quality of the surface
- ▲ Finest shiny surfaces thanks to “flowing grinding” in shortest time due to a treatment intensity 10 to 15 times higher compared with standard procedures
- ▲ Highly wear resistant special polyurethane lining with a non-stick texture for high quality parts, avoiding any mixing of parts

Dimensioned sketch Z2

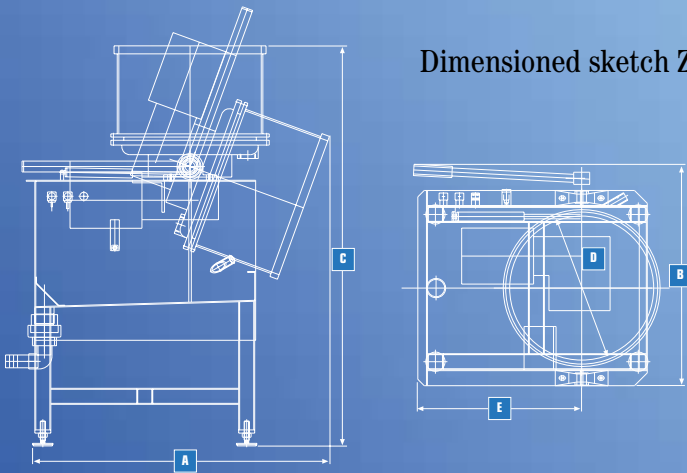

Technical data:

	Z1	Z2
Working tub volume in liters	11	30
Usable volume in liters	7	20
Rotor speed	approx. 280 rpm	approx. 280 rpm
Driving power	0,75 kW	2,2 kW
Height of the working tub	1000 mm	1250 mm
Operating voltage	400 V, 50 cycles	400 V, 50 cycles

Dimensions in mm:

	Z1	Z2
A	950	930
B	530	692
C	1000	1250
D	300	490
E	1350	512

Subject to technical modifications

Dimensioned sketch Z1

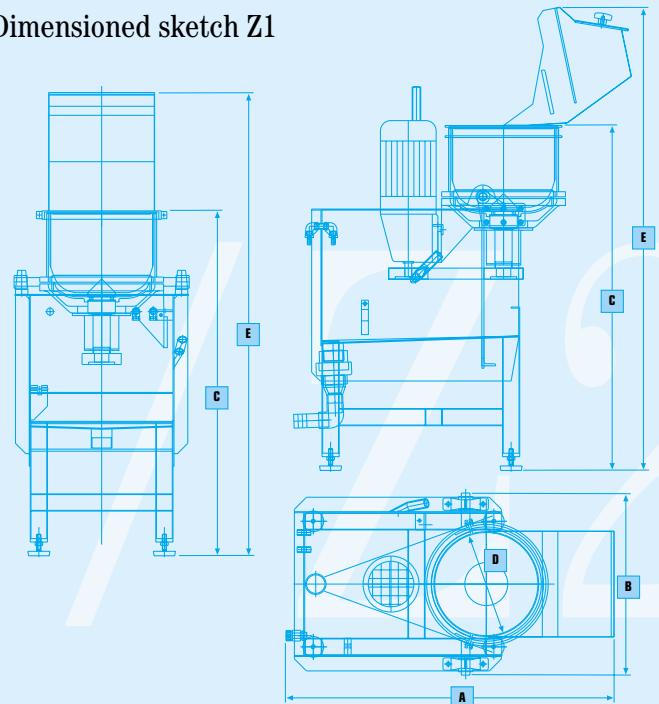

SPALECK
Oberflächentechnik

SPALECK Oberflächentechnik GmbH + Co. KG
P.O. Box 2253 · D-46372 Bocholt
Schlavenhorst 117 · D-46395 Bocholt
Telephone +49 (0) 28 71 / 95 00-0
Telefax +49 (0) 28 71 / 95 00-95
www.spaleck.biz · info@spaleck.biz